

EZ26

Tracked Zero Tail Excavators



**WACKER
NEUSON**
all it takes!



The design for champions

The compact excavator EZ26 guarantees modern design, flexibility and ease of use. Transportation by car trailer to the next construction site? No problem - the low weight allows transport including attachment tool by means of 3.5t trailer. An innovative windshield mechanism for easy ventilation provides working comfort and facilitates communication between driver and colleagues. Control lever carrier, the wide cabin entry and the arrangement of control and display elements of the EZ26 are ergonomically perfectly adapted to the needs of your workplace.

- The re-designed cabin of the EZ26 is ergonomic and spacious.
- Large, double-sided sliding windscreen.
- Magnetic rotating light (LED) which can be quickly attached and released at any time. The LED light is characterized by high luminosity and low power consumption.
- Zero tail swing for working in tight and confined spaces.
- Optional Vertical Digging System (VDS) and EASY LOCK.

EZ26 Technical specifications

Operating data

Shipping weight	2,469 - 3,161 kg
Operating weight	2,571 - 3,262 kg
Biting force max.	15.3 kN
Breakout force max.	22.5 kN
Digging depth max.	2,744 mm
Dumping height	2,840 - 3,087 mm
Digging radius max.	4,806 mm
Superstructure slewing speed	10 1/min
L x W x H	4,266 x 1,570 x 2,414 mm

Engine / Motor

Engine / Motor manufacturer	Yanmar
Engine / Motor type	3TNV76
Engine / Motor	water-cooled 3-cylinder diesel engine
Displacement	1,116 cm ³
RPM / speed	2,500 rpm
Engine performance output to ISO	15.2 kW
Battery	44 Ah
Tank capacity	36 l

Hydraulic system

Duty pump	double variable- & two-gear pump
Max. flow rate	30.5 + 30.5 l/min
Max. flow rate	20.2 + 7.2 l/min
Operating pressure for working and traction hydraulics	225 bar
Operating pressure slewing gear	206 bar
Hydraulic oil tank	26.5 l

Undercarriage

Travel speed max.	3.8 km/h
Chain width	300 mm
Ground clearance	277 mm

Dozer Blade

Width	1,570 mm
Height	290 mm
Stroke max. above ground	380 mm
Stroke max. below ground	419 mm

Sound level

Sound level (LwA) acc. to 2000/14/EC	93 dB(A)
Cabin - specified sound pressure level LpA acc. to ISO 6394	79 dB(A)

EZ26 Dimensions

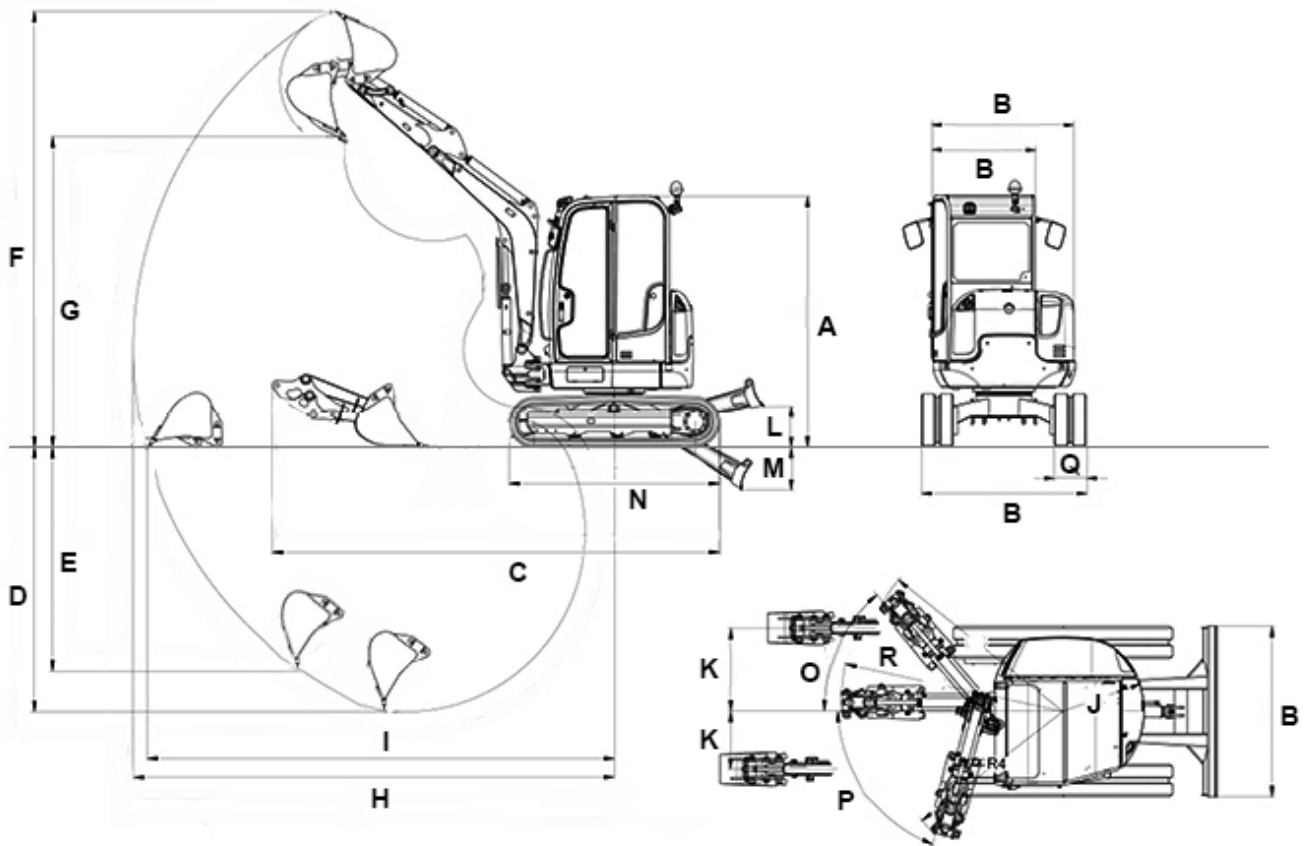

			with VDS
A	Height	2,414 mm	2,524 mm
B	Width of the cabin	970 mm	970 mm
B	Width of the revolving superstructure	1,340 mm	1,340 mm
B	Width of the undercarriage	1,570 mm	1,570 mm
C	Transport length (short DA)	4,266 mm	4,199 mm
C	Transport length (long DA)	4,272 mm	4,241 mm
D	Digging depth max. (short DA)	2,544 mm	2,418 mm
D	Digging depth max. (long DA)	2,744 mm	2,617 mm
E	Insertion depth max. vertical (short DA)	1,962 mm	1,845 mm
E	Insertion depth max. vertical (long DA)	2,152 mm	2,035 mm
F	Insertion height max. (short DA)	4,169 mm	4,300 mm
F	Insertion height max. (long DA)	4,299 mm	4,430 mm
G	Dump height max. (short DA)	2,840 mm	2,960 mm
G	Dump height max. (long DA)	2,970 mm	3,087 mm
H	Digging radius max. (short DA)	4,613 mm	4,614 mm
H	Digging radius max. (long DA)	4,805 mm	4,806 mm
I	Range max. ground coverage (short DA)	4,481 mm	4,443 mm
I	Range max. ground coverage (long DA)	4,681 mm	4,644 mm

J	Rear swivel radius	759 mm	759 mm
K	Arm displacement max. boom offset to center of bucket, right side	764 mm	765 mm
K	Arm displacement max. boom offset to center of bucket, left side	533 mm	534 mm
L	Lift height max. of dozer blade above subgrade	380 mm	388 mm
M	Scraping depth max. of the dozer blade below subgrade	419 mm	411 mm
N	Length	2,006 mm	2,006 mm
O	Turning angle max. of the arm system to the right	50 °	50 °
P	Turning angle max. of the arm system to the left	75 °	75 °
Q	Chain width	300 mm	300 mm
--	Distance of bucket dozer blade (short DA)	354 mm	326 mm
--	Distance of bucket dozer blade (long DA)	259 mm	218 mm
R	Boom slewing radius center	2,080 mm	2,054 mm
--	Boom slewing radius right	1,960 mm	1,943 mm
--	Boom slewing radius left	1,641 mm	1,640 mm
--	Length total traveling gear	2,006 mm	2,021 mm
--	Width dozer blade	1,570 mm	1,570 mm
--	Height dozer blade	300 mm	300 mm

DA = dipper arm

Please note: that product availability can vary from country to country. It is possible that information / products may not be available in your country. More detailed information on engine power can be found in the operator's manual; the stated power may vary due to specific operating conditions. Subject to alterations and errors excepted. Applicable also to illustrations.
Copyright © 2019 Wacker Neuson SE.